

Mounting Block

Installation Instructions

CAUTION: All electrical connections must be in accordance with state and local codes, ordinances, and the National Electrical Code. If you are unfamiliar with methods of installing electrical wiring and devices, secure the services of a qualified licensed electrician.

-To be installed prior to siding-

Step 1

Remove the trim ring from the Mounting Block Assembly. See Figure 1 at right.

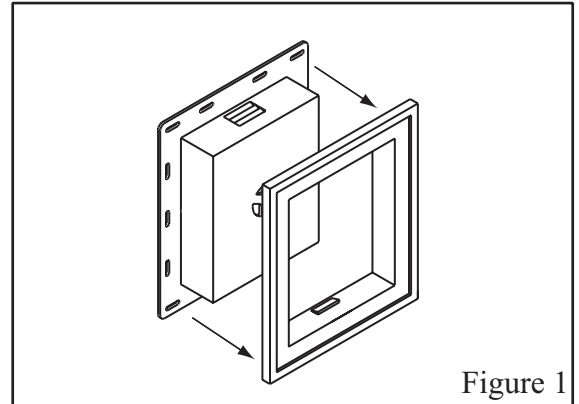

Step 2

Cut the desired opening in the Mounting Block by cutting along the patterns provided on the back of the part. See Figure 2 at right.

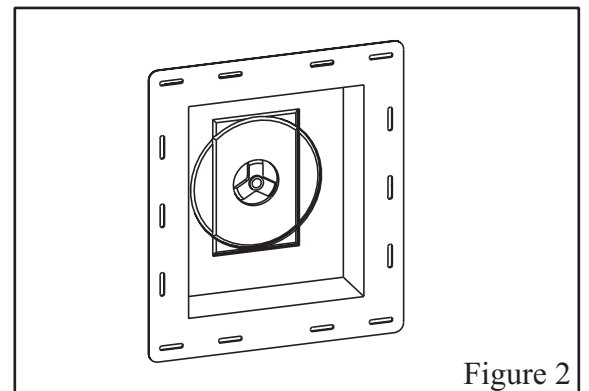

Step 3

Center the Mounting Block over the outlet box. Be sure to place tape or sealant between the Mounting Block and the house. Attach the Mounting Block securely using an 8d nail or equivalent with a minimum of four attachments. See Figure 3 at right. Note: The sheathing on the illustration at right has been removed for clarity. The outlet box should be in contact with the under side of the Mounting Block.

Note: The use of a box extension (supplied by others) may be required by your local or state electrical codes. Alternatively, the box can be repositioned so that it contacts the underside of the Mounting Block.

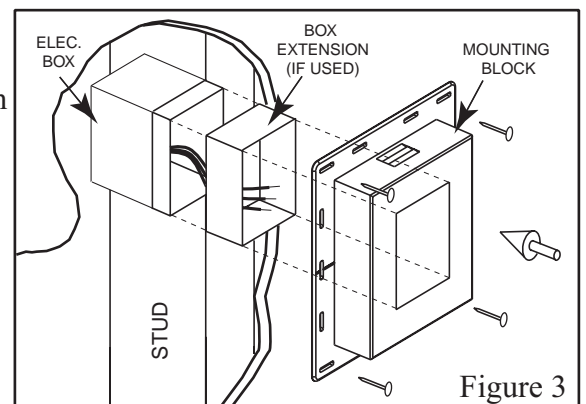

Step 4

Cut the siding around the Mounting Block. Install the siding according to the manufacturer's installation instructions. See Figure 4 at right.

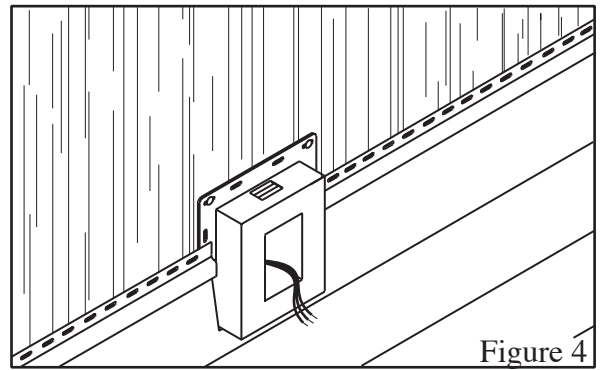

Figure 4

Step 5

Install the the trim ring by locking it into place. See Figure 5 at right.

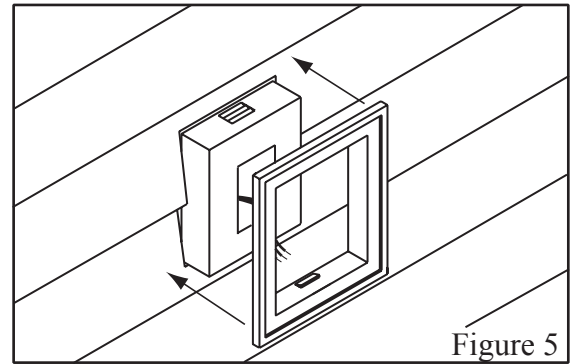

Figure 5

Step 6

Install the light fixture or electrical device per the manufacturer's installation Instructions. Be sure that all electrical product gaskets have the proper sealant. See Figure 6 at right.

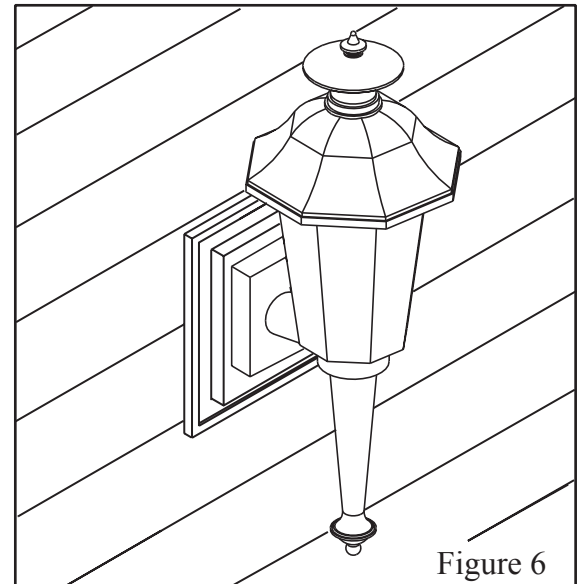

Figure 6

MA MID-AMERICA
Siding Components®
www.MidAmericaComponents.com